

1 Use the cards to complete the sentences.

_____ is the amount of space _____
 a two-dimensional shape. It can be measured in units such as
 _____ or _____

_____ is the distance _____ a two-dimensional
 shape. It can be measured in units such as _____
 or _____

2 Work out the areas and perimeters of the shapes.

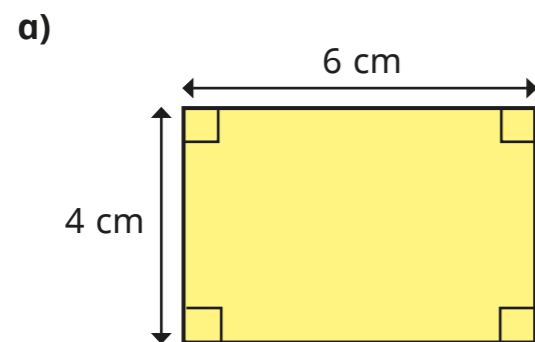

perimeter = cm
 area = cm²

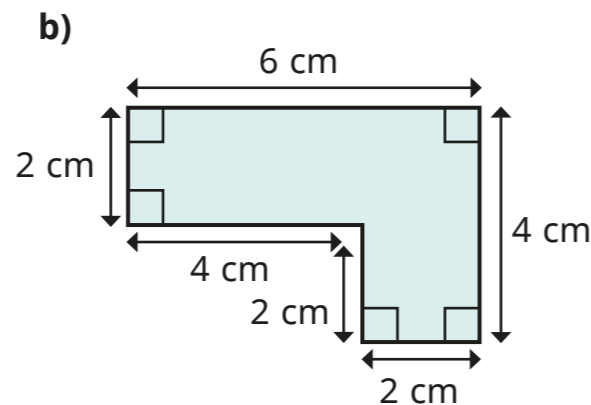

perimeter = cm
 area = cm²

3 Work out the missing values.

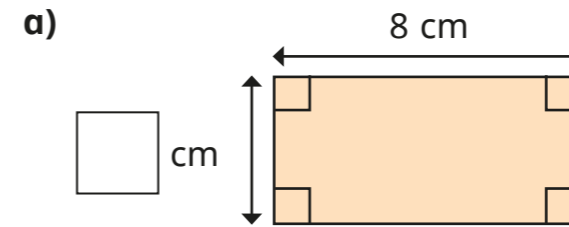

area = 32 cm²
 perimeter = cm

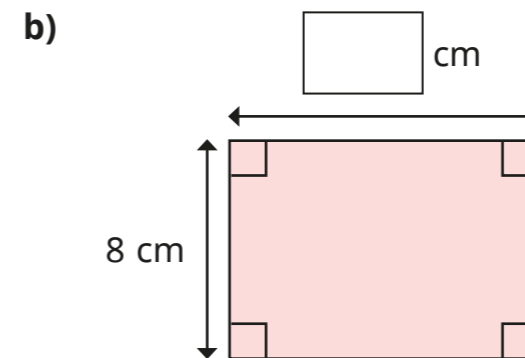

area = cm²
 perimeter = 40 cm

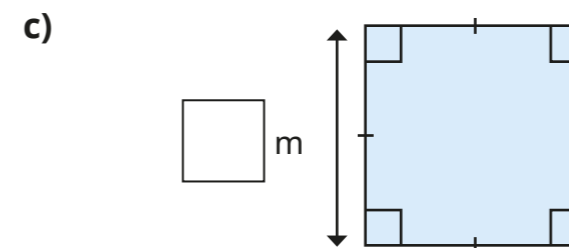

area = m²
 perimeter = 36 m

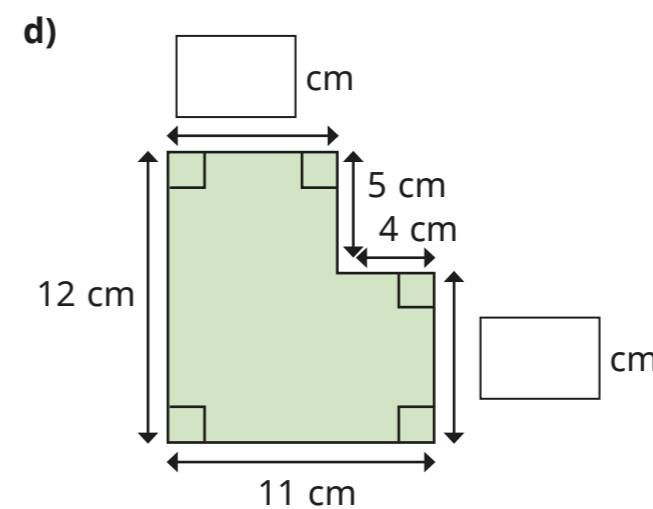

area = cm²
 perimeter = cm

4 Work out the areas and perimeters of the shapes.

a)

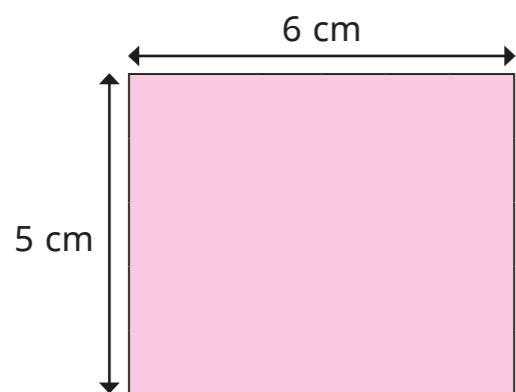

area = cm²
 perimeter = cm

b)

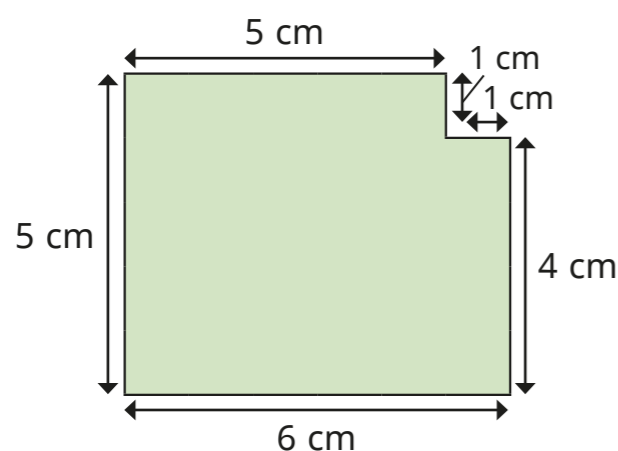

area = cm²
 perimeter = cm

What do you notice?

5 Draw two rectilinear shapes that have the same perimeter but a different area.

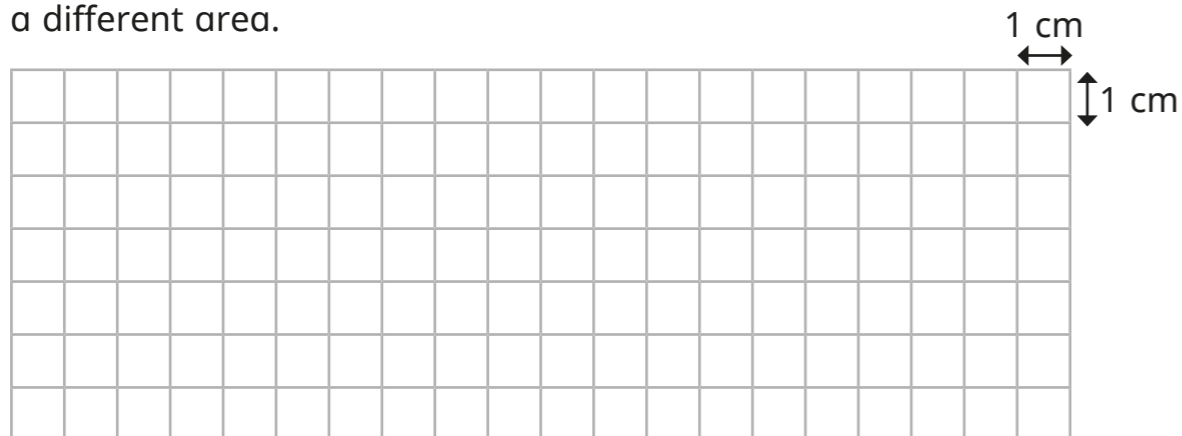

How did you do it?

Talk about it with a partner.

6 Two rectilinear shapes, A and B, each have an area of 12 cm²

- Shape A has the largest perimeter possible.
- Shape B has the smallest perimeter possible.

Draw shapes A and B.

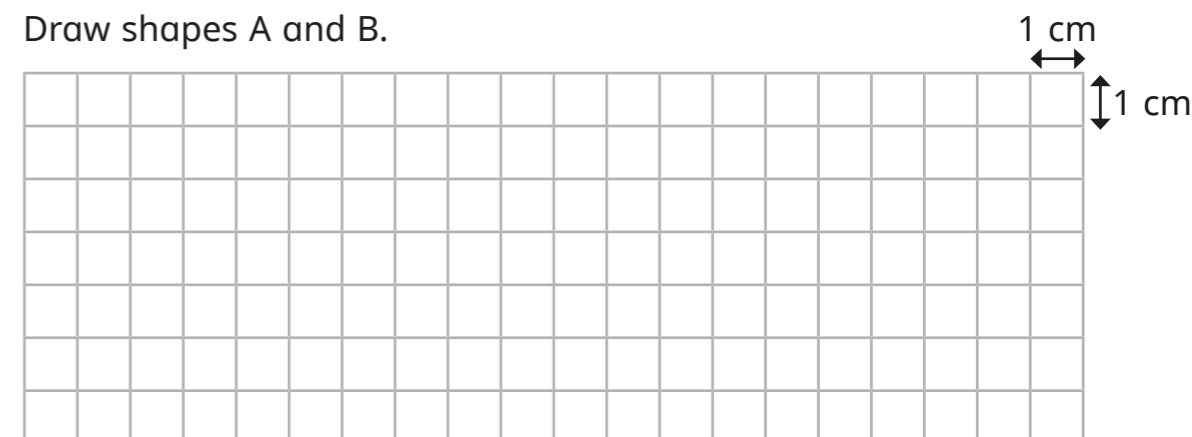

What do you notice?

7 Mr Jones has 50 m of fencing.

He wants to make a rectilinear enclosure using all the fencing. Each side of the enclosure must be a whole number of metres.

a) Draw an example of a shape he could make. Give units on your diagram.

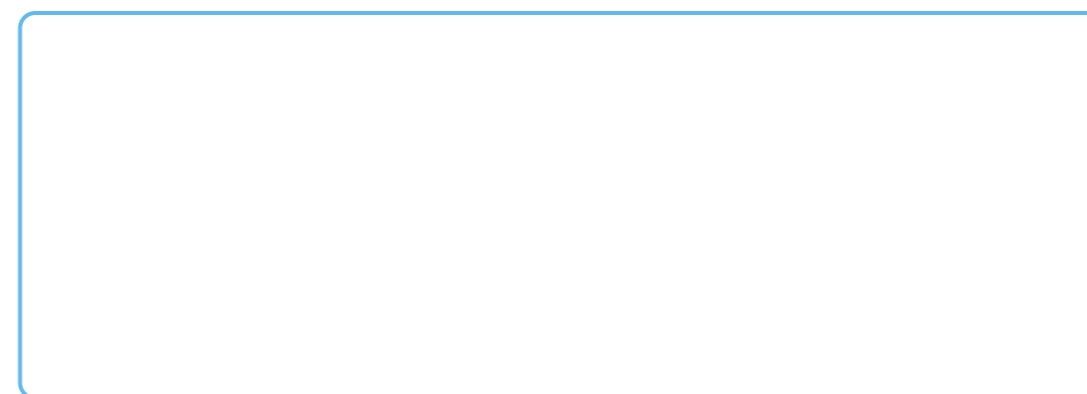

b) What is the greatest possible area of the enclosure?

c) What is the smallest possible area of the enclosure?